

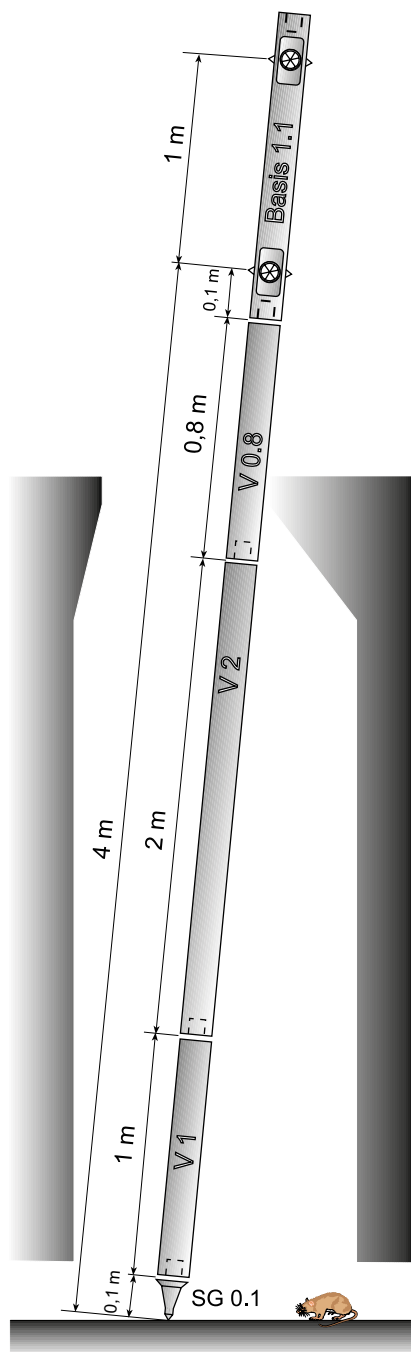

BOHNENSTINGL

Surveying Tools & Accessories

Sewer/Manhole Survey System VEKTOR



V.1. Vektor System Information

3

- Description and application possibilities
- System overview
- Material differences and accessories

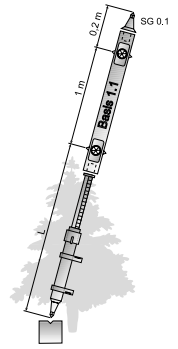
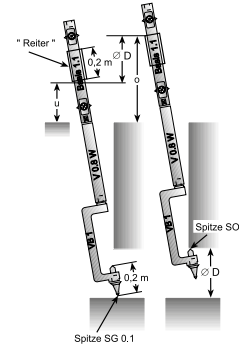
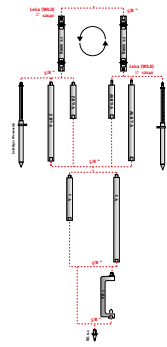
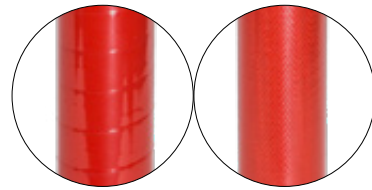

V.2. Base with integrated prisms and extensions

8

- Base with integrated prisms
- Extensions
- Tip



V.3. Accessories for Vektor System

10

- Transport bag
- Measuring bracket
- Bipod
- Circular level
- Rider
- Base extension (3rd prism)



V.4. Accessory: Boom (eccentric)

13

- General
- Height determination of manhole points
- Determination of pipe diameters

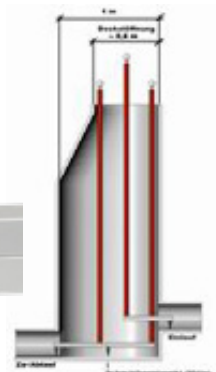

Vektor Base as attachment for standard prism pole

The **1.1 base** can be used on standard prism poles with 5/8" thread. In some cases, an adapter is necessary so the scaling on the prism pole indicates the correct height up to the lower prism („Lage I"). For the height of the upper prism 1.00 m has to be added.

Without an adapter, the **1.1. base** can be used on prism poles with Leica spigots $\varnothing 12 \times 40$ mm.

For targets close to the ground, the combination is rotated „up-side-down" 180° („Lage II"). Then the base must be equipped with a tip SG0.1 and the prism pole with a double level. The lower prism has a target height of 0.20 m and the upper one of 1.20 m.

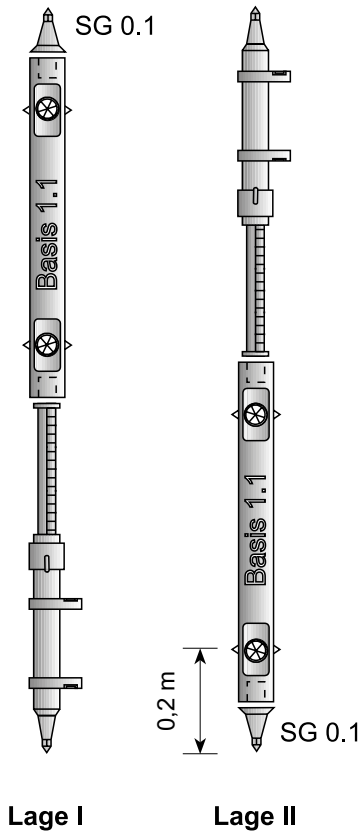

Lage I

Lage II

Vektor Base with prism pole for measuring hidden points

The combination vector base + standard prism pole is also ideally suited for measuring hidden points.

The coordinates X, Y, Z of prisms 1 and 2 are determined tachymetrically. With the target height L (reading at the scale of the standard prism pole) the 3-D coordinates of the hidden point can be calculated. The prism pole can be inclined at any angle. Only the tip must lie on the object point P and the two prisms must be aligned with the tachymeter. Of course, the position of the prism pole must not be changed between the measurement of prism 1 and 2.

This makes the use of a tripod mandatory (tripod s. page 12).

They can be used wherever points are difficult to access or a prism cannot be held upright, e.g. object points hidden by obstacles, inside corners of rooms, eaves heights, etc. The point to be measured can be targeted both in „Lage I" and in „Lage II", whereby „Lage II" in particular allows very precise coordination due to the short length of $L = 0.2$ m.

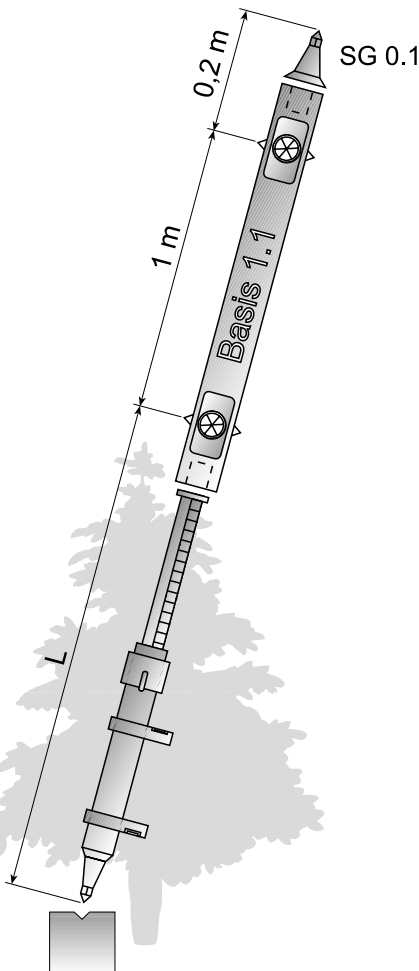

Vektor System as manhole and sewer pole

The principle of the operation is the same as for the measurement of hidden points. But when measuring „manhole depth points“ (channel bottoms, inlets, etc.), the use of normal prism poles as extensions is no longer sufficient.

Commercially available telescopic prism poles with several pull-outs have the following disadvantages:

- High weight
- Length often not sufficient
- Unstable (sag too large)
- Clamping between the individual telescopic parts too unsafe
- Scale too inaccurate
- No possibility to determine pipe diameters

All these disadvantages do not occur with the **extensions V of the Vektor system**. Due to the outstanding characteristics of the carbon fibre pole, an extension up to more than 6 m is easily possible.

Basically all system parts are connected with 5/8" threads.

Only the connection of the base to the first extension V0.8 W or V1.8 W takes place on the side with the Leica socket $\text{Ø}12 \times 40 \text{ mm}$.

It is required when using the measuring bracket (see next page); all other sections are again screwed together with 5/8" threads.

The combination base 1.1 + extension V0.8 + tip SG 0.1 has a usable length of 1 m (= distance lower prism to pole tip). With the V1 and V2 extensions, it can be extended **in full 1 m or 2 m steps as required**.

EXAMPLES

Base 1.1 + 4 m extension Carbon (V08Z, V2, V1, SG 0.1):

Weight around 2,8 kg

Base 1.1 + 4 m extension hybrid material -Carbon/GFK- (V08Z, V2, V1, SG 0.1):

Weight around 3,1 kg

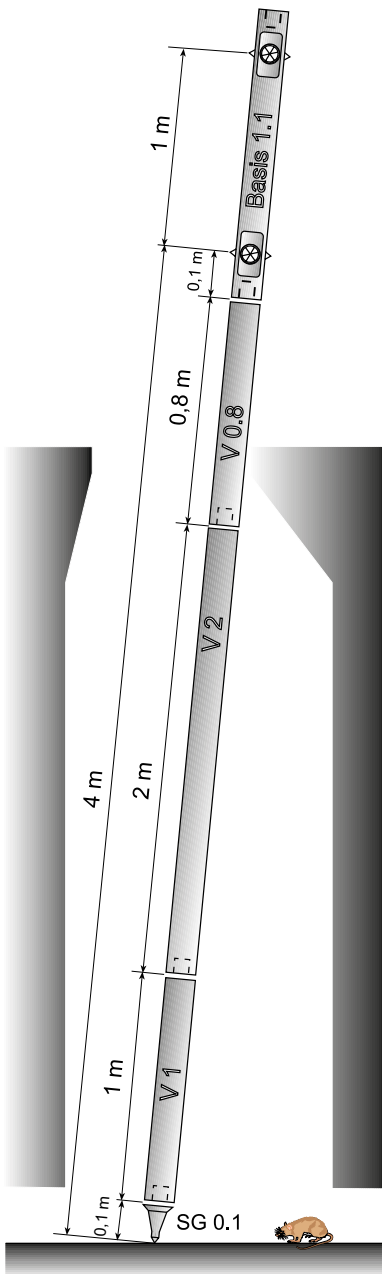

Additional determination of pipe diameters with the use of a measuring bracket VB1

Often all channel data could be measured without going down the manhole if the determination of the nominal diameters of the sewer and the inlets would be possible from above.

This problem is solved by the measuring bracket VB1:

- Can be screwed onto extensions V0.8, V1 or V2 with 5/8" thread
- Extremely light and rigid due to carbon fibre construction and aluminium profile
- Additional tips SO for measuring pipe apices

The internal diameter D can be determined for pipes with $D > 0.2$ m.

This is possible in 2 ways:

1. Measurement of pipe diameter D on site

(The base 1.1 W is equipped with a „slide“, a 20 cm long plastic sleeve that can be moved between the two prisms).

- Placing the canal measuring pole on the pipe bottom with tip **SG 0.1**.
---> Reading the vertical distance u of Slider **bottom** edge up to reference level (street) with pocket rule or tape measure. To do this, the Slider is moved to a „round“ dimension for easier calculation. (for example 0.9 m).
- Mount the sewer measuring pole with **tip SO** at the apex of the pipe.
---> Reading the vertical distance o of Slider **top** edge up to reference level (for example 1.3 m).
- pipe diameters $D = o - u$ (for example $D = 1.3 \text{ m} - 0.9 \text{ m} = 0.4 \text{ m}$).

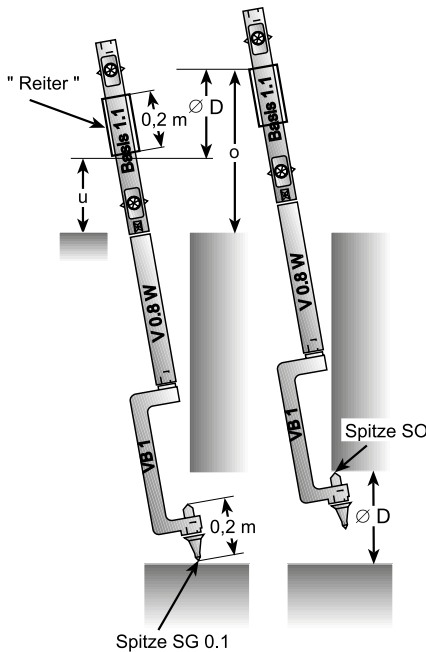

2. Determination with tachymeter

- Mount the sewer measuring pole with **tip SG 0.1** at the apex of the pipe.
---> Calculation of coordinates X, Y, Z of point P_{Sohle} by measuring prism 1 and 2 and input of the extension dimension L_u (z. B. $L_u = 2$ m).
- Mount the sewer measuring pole with **So** at the apex of the pipe.
---> Calculation of coordinates X, Y, Z of point P_{Scheitel} analog point P_{Sohle} by input of the extension dimension of $L_o = L_u - 0,2$ m (example: $L_o = 1.8$ m).
- Pipe diameter $D = ZP_{\text{(Scheitel)}} - ZP_{\text{(Sohle)}}$

In order to align the base with the synchronously tiltable prisms independently of the VB1 measuring bracket on the total station, a sensible use of the measuring bracket is only possible in combination with the base 1.1 W + V0.8 W or V1.8W (Leica spigot).

Between the extension V0.8 W / V1.8W and the measuring bracket VB1 any extensions V1 and V2 can be added (5/8"-thread).

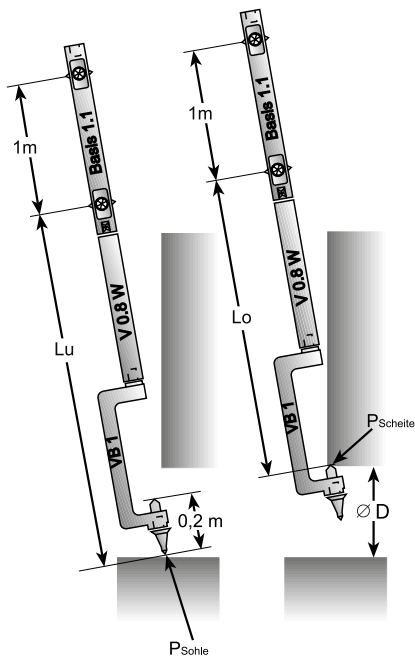

System Overview

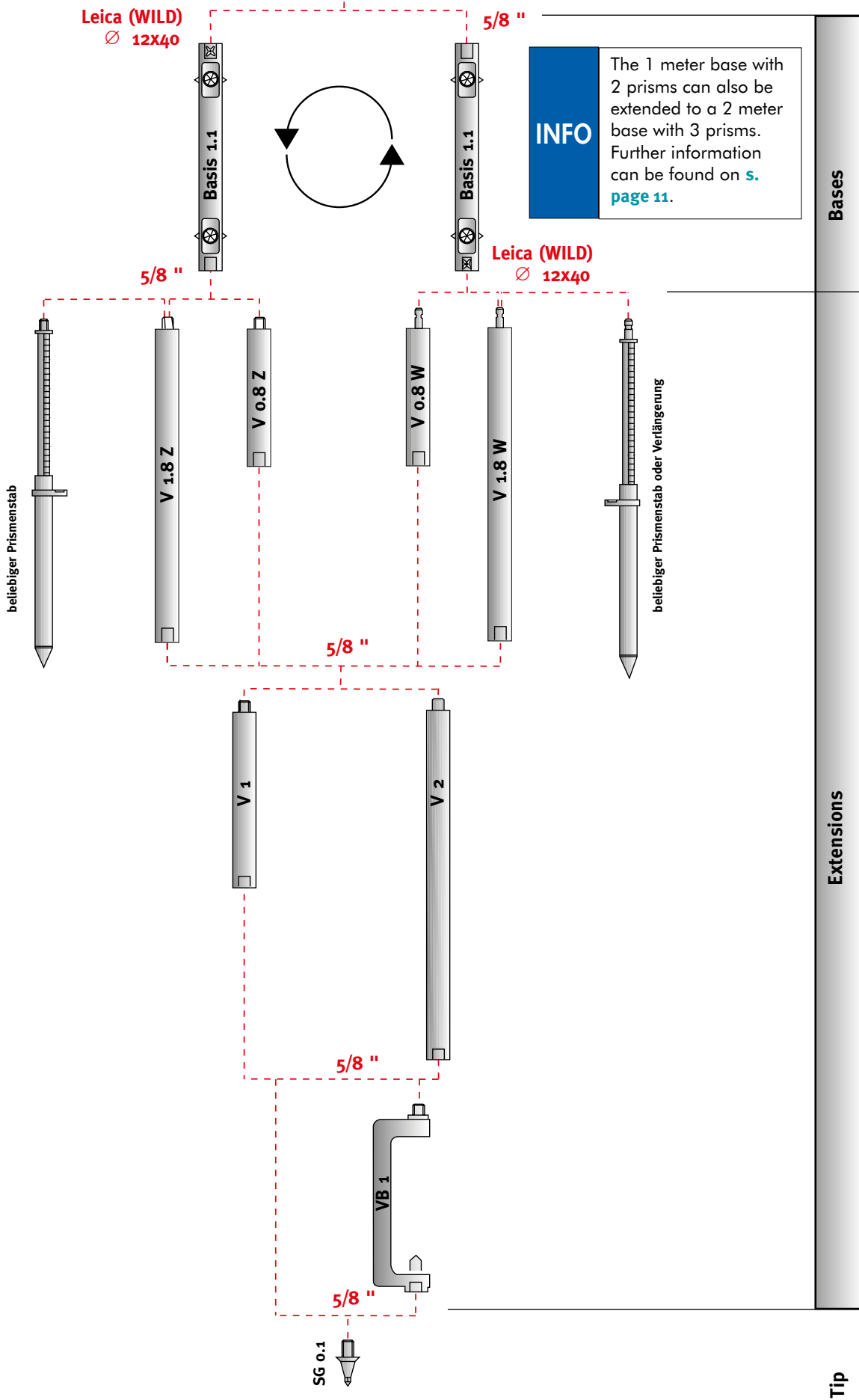



Material and Characteristics

The bases and extensions of the Vektor system are available in two different materials. Vektor bases (element with two integrated prisms) will be available only in carbon/glass fibre hybrid material from mid-2024 on.

Composite: 100 % carbon fiber (carbon, CFK)

- Outer-Ø 44 mm, Inner-Ø 40 mm
- Unrivalled light (around 40% lighter than aluminium)
- High bending stiffness
- Not permanently deformable (100% resetting to original shape even after extreme stress)
- Around 100 times lower coefficient of expansion than aluminium (temperature)
- No corrosion
- Pleasant handling even in cool weather conditions
- New since 2017: impact-resistant, wrapped cover, signal red
- All extensions are waterproof
- Thread and thread inserts made of stainless steel
- 100% Carbon as base material



Hybrid: Carbon-/Glass fibre (CFK/GFK)

Properties of the hybrid material same as the poles which are made of 100% carbon, but:

- Slightly higher weight (nevertheless approx. 15% lighter than aluminium)
- Red outer layer
- Lower material price

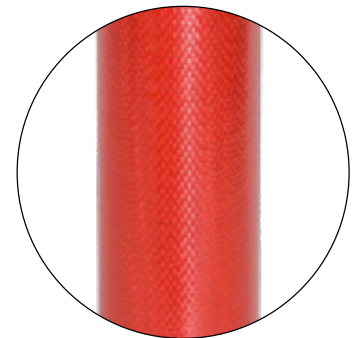

INFO

As of (estimated) mid-2024, Vector bases will only be offered as hybrid carbon/fiber designs. The extensions (2 m, 1.8 m, 1 m, 0.8 m) will continue to be available in full carbon material though.

Special features of the prism base

■ Synchronous tilting of the two prisms

The tilting takes place either:

- With a rocker arm at the back (prism constant $K = -11,3$ and $-16,9$ mm)
- Or by using the prism housing (prism constant $K = -30$, $-34,4$ and -35 mm)

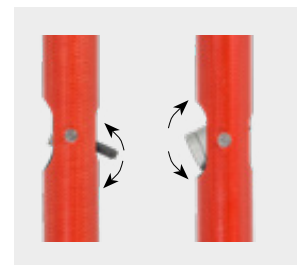

■ Red marked prism centers



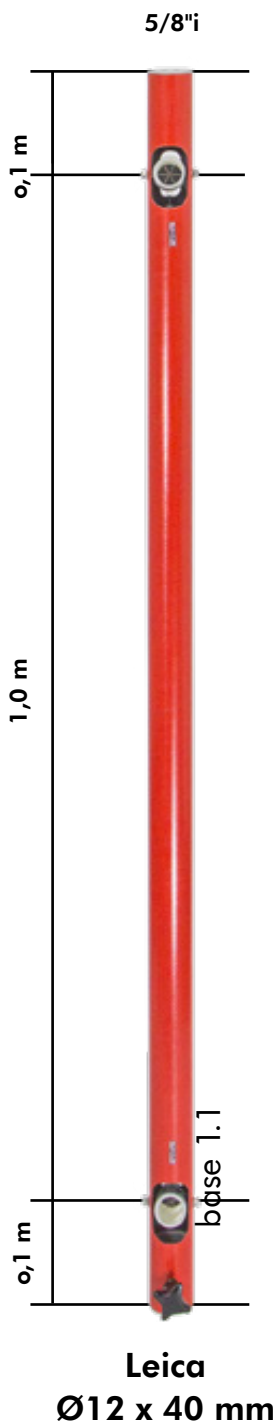

Prism base for the Vektor System

- Prism body fully integrated in pole body
- Inserts made of aluminium, internal thread 5/8" made of stainless steel
- All glass prisms \varnothing 25 mm (except prism constant -11,3 mm: \varnothing 17,5 mm)
- Prisms equipped with red marked prism centre (see previous page)

INFO

For all constants, the tilting and vertical axis runs through the red marked visible prism centre (centrally symmetric point).

■ 2 connections: Leica socket & 5/8" inner thread

The base can be put onto the extension V0.8W or V1.8W with the spigot connection. It is secured with a horizontal screw with star grip.

If you turn the base around you alternatively can use the 5/8" inner thread.

Vektor Base 1.1				
Material	approx. Weight	Prism Constant K	Order-No.	Euro
Hybrid Carbon / GFK	870 g	-11,3 (Leica = +23,1) mm	3004.11	987,-
	870 g	-16,9 (Leica = +17,5) mm	3004.17	987,-
	870 g	-30 (Leica = +4,4) mm	3004.30	1.040,-
	870 g	-34,4 (Leica = 0) mm -35,0 (Leica = -0,6) mm	3004.34	1.050,-

INFO

As of 2024, Vector bases will only be offered as hybrid carbon/fiber designs. The extensions (2 m, 1.8 m, 1 m, 0.8 m) will continue to be available in full carbon material though.



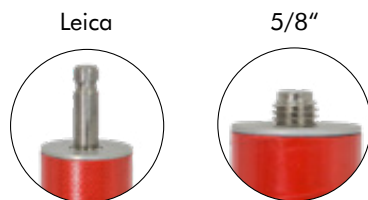

Extensions

All extensions have a 5/8" stainless steel thread at the top and a 5/8" female thread with stainless steel insert at the bottom. Exceptions are V0.8 W and V1.8 W, which have a stainless steel spigot \varnothing 12 x 40 mm at the top.

First extension

The first extension of the base is 0.8 m or 1.8 m long. Together with the 0.1 m at the base and the top (0.1 m) results in a full m-amount.

■ When using the Leica socket of the base

Description	Material	Weight	Order-No.	Euro
Extension V 0.8 W Length = 0.8 m	Carbon	450 g	2014	344,-
	Carbon / GFK	490 g	3014	238,-
Extension V 1.8 W Length = 1.80 m	Carbon	810 g	2054	559,-
	Carbon / GFK	890 g	3054	344,-

■ When using the 5/8" inner thread of the base

Description	Material	Weight	Order-No.	Euro
Extension V 0.8 Z Length = 0.80 m	Carbon	450 g	2012	344,-
	Carbon / GFK	490 g	3012	238,-
Extension V 1.8 Z Length = 1.80 m	Carbon	810 g	2053	559,-
	Carbon / GFK	890 g	3053	344,-



Further extensions in m-steps

Description	Material	Weight	Order-No.	Euro
Extension V 1 Length = 1,00 m	Carbon	500 g	2051	382,-
	Carbon / GFK	600 g	3051	254,-
Extension V 2 Length = 2,00 m	Carbon	940 g	2052	604,-
	Carbon / GFK	1020 g	3052	361,-



Tip

Aluminium turned part with V2A base and hardened tip.
Effective length: 10 cm (without 5/8" thread).

Description	Order-No.	Euro
Tip SG 0.1 (around 120 g)	2050	43,-

Accessories for System VEKTOR

Measuring bracket VB1

■ For the determination of pipe diameters

Application description [s. page 5.](#)

Bracket arm made of aluminium profile. Additional tip for apex made of aluminium/stainless steel. Length 1.00 m. Including Slider No. 2056 (see below).

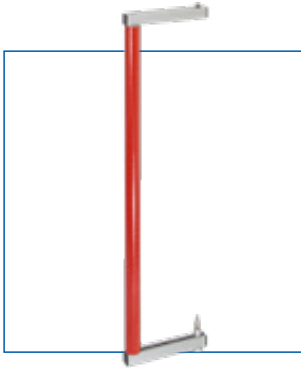

Description	Order-No.	Euro
Measuring bracket VB 1 Carbon (around 1100 g)	2055	532,-
Measuring bracket VB 1 Hybrid - Carbon/GFK (around 1250 g)	3055	396,-

INFO

When using the VB1 measuring bracket, it is necessary to use a extension 0.8 m or 1.8 m **with Leica connection/spigot** [s. page 9.](#)



Slider

For use at the base for the determination of pipe diameters [s. page 5](#) Plastic sleeve with Velcro fastener. Length 0.2 m.

Description	Order-No.	Euro
Slider for Vektor base	2056	11,-

Transportation bag for Vektor poles

For transport and storage of Vektor equipment; for pole lengths up to 8 m. Durable synthetic fibre material with 4 separate storage compartments. Dimensions: 2.20 m x 0.40 m



Description	Order-No.	Euro
Transportation bag TTV	2010	86,-

Base-Extension / 3. Prism

Extension of a 1-m-Base with 2 prisms to a 2-m-Base with 3 prisms

The base extension 1.0 W is connected to the standard base 1.1 W with the Leica stud bolt (spigot) connection $\text{Ø}12 \times 40$ mm. The result is a 2-m-base with 3 prisms, with a spacing of 1000 mm between prisms.

The base extension 1.0 W also has a Leica stud mounting socket at the bottom, so that only the V 0.8 W or the V 1.8 W can be used as the 1st extension. All other extensions are then made as usual with a 5/8" thread.

- Top connection: Leica spigot $\text{Ø}12 \times 40$ mm
- Bottom connection: Leica stud mount (socket)
- Manual prism tilting adjustment ([s. page 7](#))

Please ensure that identical prism constants of base and extension are used.

Base-Extension 1.0 W				
material	approx. weight	prism constant K	Order-No.	Euro
Mixed material Carbon / GRP	720 g	-11,3 (Leica = +23,1) mm	3009.11	709,-
	730 g	-16,9 (Leica = +17,5) mm	3009.17	709,-
	740 g	-30 (Leica = +4,4) mm	3009.30	735,-
	750 g	-34,4 (Leica = 0) mm -35,0 (Leica = -0,6) mm	3009.34	740,-

INFO

A 2-m base with 3 prisms can be extended by an additional prism in 1-m increments with further extensions.





Universal strut bipod with quick connector

2-legged stand for:

- Prism poles
- GNSS antenna pole
- Sewer poles (for example Vektor)



Advantages

- Clamping connection for all poles with diameters from 32 to 50 mm
- The strut bipod can be clamped to the pole in seconds
- No complicated and time-consuming „insertion“ of the pole from above
- Telescopic legs and ball head for easy vertical positioning even on uneven ground
- Reliable mounting of inclined poles, e.g. prism pole Vektor when used as sewer measuring pole
- Sturdy lightweight aluminium construction with red warning paint and entry surfaces

Description	Order-No.	Euro
Universal strut stand, 2 telescopic legs, quick connection	2095	315,-

Circular level Vektor System

General information:

With the insertion circular level, the universal prism pole Vektor can be used vertically for further applications:

- Prism pole with large reflector heights
- Antenna pole for GPS measurements with high antenna height

The prism base can also be dispensed and only Vektor extensions can be used. The big advantages of the Vektor System, **-light, sturdy, precise-** are also fully effective in this application.

If desired, an extension can be adapted in length to your antenna type, so that the antenna height is always exactly round m values. Reading errors, as they can occur with telescopic slides, are thus ruled out.

Setup:

The circular level is embedded in a stable, adjustable aluminium housing. It can be used between any 5/8" screw connection of the Vektor system. Large contact surfaces ensure an exact connection to the vector pole.

The technical features of the circular level itself:

- Metal casing with 20 mm diameter
- Ground glass with 10' accuracy

This allows accurate measurements even with large prism or antenna heights.

Description	Order-No.	Euro
Insertion circular level EDL 10'	2040.10	74,-



Boom (eccentric) for Sewer / Prism poles

The position and height of the shaft points are determined by ordinarily with a sewer pole. When using our Vektor system [s. page 8](#) the pole stands inclined in the shaft, the two prisms of the base are measured and the software calculates the coordinates of the pole tip after entering the extension length.

With the help of the measuring bracket VB1 pipe diameters of outlets and inlets can also be determined.

If the position of the manhole is already known, it may be necessary to determine or check the heights of points in the shaft. The described use of the 2-prism method is not absolutely necessary for this.

Height determination of manhole points with boom

With our boom and the help of vertical poles points in the manhole can be determined in height (not in position though).

For example, with a set boom length of approx. 45 cm, all points of a normed manhole DN 1000 can be measured (see sketch).

The point height itself can be determined in various ways (also depending on the accuracy requirement):

- Reading of the cut-off dimension at the top edge of the lid opening (lid height must be known)
- Measurement of a prism mounted onto the pole by a total station (input of the pole length as reflector height)
- Determination with a GNSS antenna mounted on the pole (taking into account the pole length)

■ Can be used on all poles with a removable 5/8" tip

- Poles with 5/8" female thread at bottom and tips with 5/8" male thread, e.g. system Vektor
- Poles with 5/8" male thread at bottom and 5/8" female thread tips, e.g. many prism poles

■ Setup & Features

- Can be used on all poles with removable 5/8" tip
- Sturdy profile made of anodised aluminium
- Telescopic from 0.38 m to 0.60 m, continuously variable (stepless)
- M8 stainless steel male thread centrally above the tip for screwing on the optional upper tip (see next page)
- Weight: 850 g

Description	Order-No.	Euro
Boom (eccentric) for determining the sewer / inlet height, 5/8"	2058	146,-

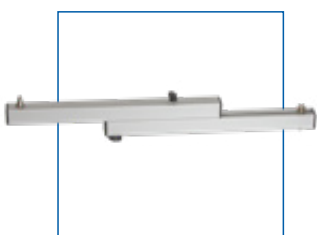
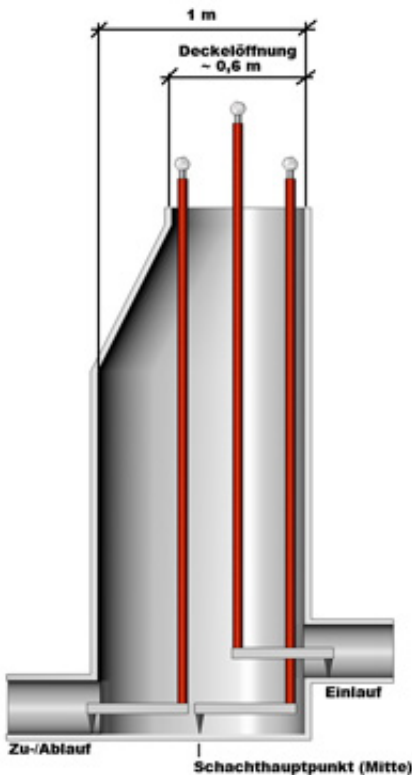

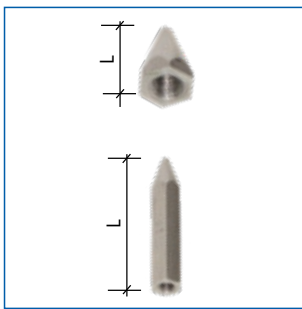
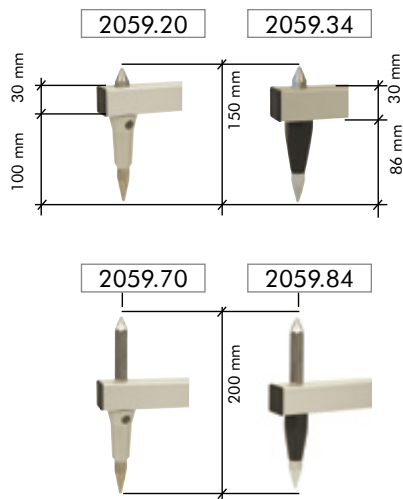

Determination of pipe diameters

Another feature is the determination of pipe diameters (nominal widths) from 15 cm. This requires a 2nd tip pointing upwards, which is available as an option.

■ Upward Tip

- Stainless steel hexagon, for mounting with wrench SW13
- M8 internal thread for screwing onto the extension arm / boom

Depending on the minimum diameter from which inlets are to be determined, the corresponding length of the **upper tip** must be selected so that a round distance measure between the two tips results.

Length of the bottom tip: 50 mm (Order-No. 1859.100)
 86 mm with prism pole S10
 100 mm with Vektor System poles

Description	when length of the lower tip is	distance AS between upper and bottom tip	Order-No.	Euro
upper tip L = 20 mm	50 mm	100 mm	2059.20	14,-
	100 mm	150 mm	2059.20	14,-
upper tip L = 34 mm	86 mm	150 mm	2059.34	15,-
upper tip L = 70 mm	100 mm	200 mm	2059.70	18,-
Obere Spitze L = 84 mm	86 mm	200 mm	2059.84	19,-

The distance AS from lower to upper tip is the smallest measurable tube diameter.

Measurement methods

■ With vertically standing pole

1. Determination of the difference via the two measured points P_{Sohle} and P_{Scheitel}

$$D = \text{measurement point } P_{\text{Sohle}} - \text{measurement point } P_{\text{Scheitel}} + \text{distance AS}$$

2. Determination of the heights (Z-coordinates) of point P_{Sohle} and P_{Scheitel} with the tachymeter by means of a prism attached to the pole.

3. Determination of the heights (Z-coordinates) of point P_{Sohle} und P_{Scheitel} with the help of a GNSS antenna mounted on the pole.

Please note for 2. and 3.: The target height of the measurement P_{Scheitel} is different from the measurement P_{Sohle} and the distance of **AS** lower.

The pipe diameter D is then calculated according to the following formula:

$$D = \text{height } P_{\text{Scheitel}} - \text{height } P_{\text{Sohle}}$$

$$D = \text{height } P_{\text{Sohle}} - \text{height } P_{\text{Scheitel}}$$

